

OS2

Long-Range High-Resolution Imaging Lidar

FIRMWARE VERSION: v2.5.x

HARDWARE VERSION: REV7

SUMMARY

The long-range OS2 features 200 m of range on a dark 10% target and a maximum range of over 400 m. The OS2's high resolution combined with range delivers superior object detection capabilities for autonomous vehicles and long-range industrial applications. Rated IP68/69K for all weather conditions.

HIGHLIGHTS

- 100% increase in range with the new L3 Chip
- Dual Return mode
- Fixed resolution per frame
- Camera-grade near-infrared and signal data
- Multi-sensor crosstalk suppression
- Open source ROS and C++ drivers
- Ouster SDK for software development

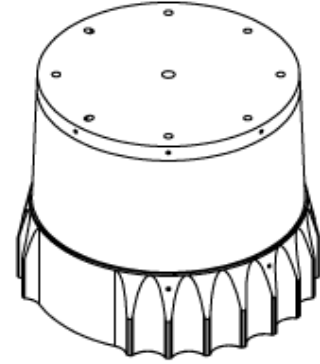

OPTICAL PERFORMANCE

Range (80% Lambertian reflectivity, 1024 @ 10 Hz mode)	350 m @ >90% detection probability, 100 klx sunlight
Range (10% Lambertian reflectivity, 1024 @ 10 Hz mode)	200 m @ >90% detection probability, 100 klx sunlight
Minimum Range	0.8 m
Vertical Resolution	32, 64, or 128 channels
Horizontal Resolution	512, 1024, or 2048 (configurable)
Rotation Rate	10 or 20 Hz (configurable)
Field of View	Vertical: 22.5° (+11.25° to -11.25°) Horizontal: 360°
Angular Sampling Accuracy	Vertical: ±0.01° / Horizontal: ±0.01°
False Positive Rate	1/10,000
Range Resolution	0.1 cm Note: For <i>Low Data Rate Profile</i> the Range Resolution = 0.8cm
# of Returns	2 (strongest, second strongest)

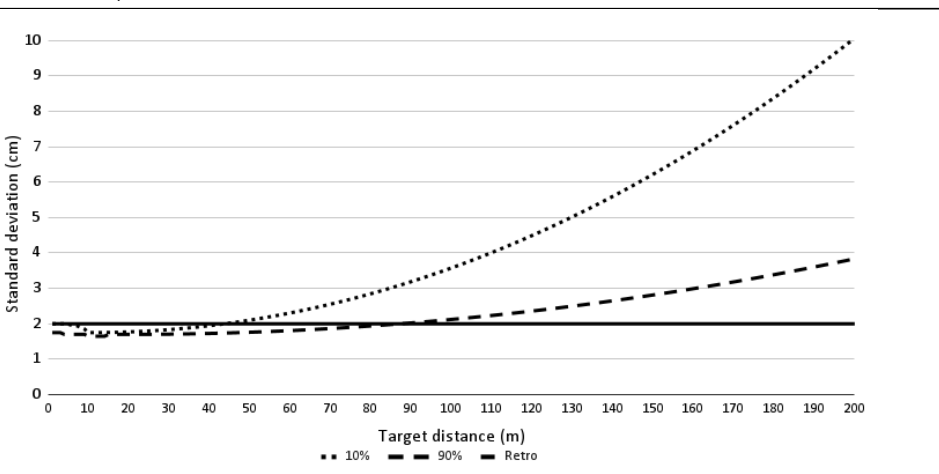
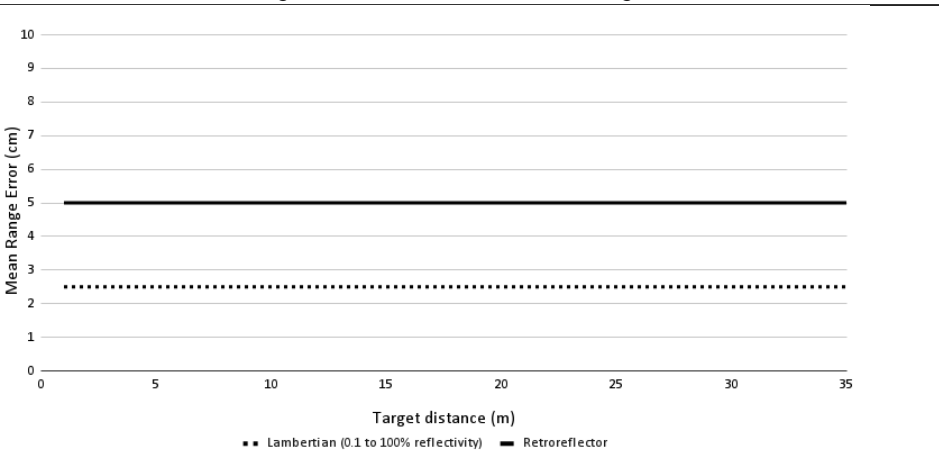
<p>Precision (Lambertian and Retro reflective, 1024 @ 10 Hz mode, 1 standard deviation)</p>	<p>Min: ± 2.0cm, Max: ± 10</p>  <table border="1"> <caption>Standard deviation (cm) vs Target distance (m)</caption> <thead> <tr> <th>Target distance (m)</th> <th>10% (cm)</th> <th>90% (cm)</th> <th>Retro (cm)</th> </tr> </thead> <tbody> <tr><td>0</td><td>2.0</td><td>2.0</td><td>2.0</td></tr> <tr><td>10</td><td>2.0</td><td>2.0</td><td>2.0</td></tr> <tr><td>20</td><td>2.0</td><td>2.0</td><td>2.0</td></tr> <tr><td>30</td><td>2.0</td><td>2.0</td><td>2.0</td></tr> <tr><td>40</td><td>2.0</td><td>2.0</td><td>2.0</td></tr> <tr><td>50</td><td>2.2</td><td>2.0</td><td>2.0</td></tr> <tr><td>60</td><td>2.5</td><td>2.0</td><td>2.0</td></tr> <tr><td>70</td><td>3.0</td><td>2.0</td><td>2.0</td></tr> <tr><td>80</td><td>3.5</td><td>2.0</td><td>2.0</td></tr> <tr><td>90</td><td>4.0</td><td>2.1</td><td>2.0</td></tr> <tr><td>100</td><td>4.5</td><td>2.2</td><td>2.0</td></tr> <tr><td>110</td><td>5.0</td><td>2.3</td><td>2.0</td></tr> <tr><td>120</td><td>5.5</td><td>2.4</td><td>2.0</td></tr> <tr><td>130</td><td>6.0</td><td>2.5</td><td>2.0</td></tr> <tr><td>140</td><td>6.5</td><td>2.6</td><td>2.0</td></tr> <tr><td>150</td><td>7.0</td><td>2.7</td><td>2.0</td></tr> <tr><td>160</td><td>7.5</td><td>2.8</td><td>2.0</td></tr> <tr><td>170</td><td>8.0</td><td>2.9</td><td>2.0</td></tr> <tr><td>180</td><td>8.5</td><td>3.0</td><td>2.0</td></tr> <tr><td>190</td><td>9.0</td><td>3.1</td><td>2.0</td></tr> <tr><td>200</td><td>9.5</td><td>3.2</td><td>2.0</td></tr> </tbody> </table>	Target distance (m)	10% (cm)	90% (cm)	Retro (cm)	0	2.0	2.0	2.0	10	2.0	2.0	2.0	20	2.0	2.0	2.0	30	2.0	2.0	2.0	40	2.0	2.0	2.0	50	2.2	2.0	2.0	60	2.5	2.0	2.0	70	3.0	2.0	2.0	80	3.5	2.0	2.0	90	4.0	2.1	2.0	100	4.5	2.2	2.0	110	5.0	2.3	2.0	120	5.5	2.4	2.0	130	6.0	2.5	2.0	140	6.5	2.6	2.0	150	7.0	2.7	2.0	160	7.5	2.8	2.0	170	8.0	2.9	2.0	180	8.5	3.0	2.0	190	9.0	3.1	2.0	200	9.5	3.2	2.0
Target distance (m)	10% (cm)	90% (cm)	Retro (cm)																																																																																						
0	2.0	2.0	2.0																																																																																						
10	2.0	2.0	2.0																																																																																						
20	2.0	2.0	2.0																																																																																						
30	2.0	2.0	2.0																																																																																						
40	2.0	2.0	2.0																																																																																						
50	2.2	2.0	2.0																																																																																						
60	2.5	2.0	2.0																																																																																						
70	3.0	2.0	2.0																																																																																						
80	3.5	2.0	2.0																																																																																						
90	4.0	2.1	2.0																																																																																						
100	4.5	2.2	2.0																																																																																						
110	5.0	2.3	2.0																																																																																						
120	5.5	2.4	2.0																																																																																						
130	6.0	2.5	2.0																																																																																						
140	6.5	2.6	2.0																																																																																						
150	7.0	2.7	2.0																																																																																						
160	7.5	2.8	2.0																																																																																						
170	8.0	2.9	2.0																																																																																						
180	8.5	3.0	2.0																																																																																						
190	9.0	3.1	2.0																																																																																						
200	9.5	3.2	2.0																																																																																						
<p>Range Accuracy (Typical on Lambertian and Retroreflective targets beyond 1m, 1024 @ 10 Hz mode) Note: "Accuracy is calculated based on the error between the mean of 100 measurements on a static target at a given range and the true range"</p>	<p>± 2.5 cm for lambertian targets, ± 5cm for retroreflective targets</p>  <table border="1"> <caption>Mean Range Error (cm) vs Target distance (m)</caption> <thead> <tr> <th>Target distance (m)</th> <th>Lambertian (0.1 to 100% reflectivity) (cm)</th> <th>Retroreflector (cm)</th> </tr> </thead> <tbody> <tr><td>0</td><td>2.5</td><td>5.0</td></tr> <tr><td>5</td><td>2.5</td><td>5.0</td></tr> <tr><td>10</td><td>2.5</td><td>5.0</td></tr> <tr><td>15</td><td>2.5</td><td>5.0</td></tr> <tr><td>20</td><td>2.5</td><td>5.0</td></tr> <tr><td>25</td><td>2.5</td><td>5.0</td></tr> <tr><td>30</td><td>2.5</td><td>5.0</td></tr> <tr><td>35</td><td>2.5</td><td>5.0</td></tr> </tbody> </table>	Target distance (m)	Lambertian (0.1 to 100% reflectivity) (cm)	Retroreflector (cm)	0	2.5	5.0	5	2.5	5.0	10	2.5	5.0	15	2.5	5.0	20	2.5	5.0	25	2.5	5.0	30	2.5	5.0	35	2.5	5.0																																																													
Target distance (m)	Lambertian (0.1 to 100% reflectivity) (cm)	Retroreflector (cm)																																																																																							
0	2.5	5.0																																																																																							
5	2.5	5.0																																																																																							
10	2.5	5.0																																																																																							
15	2.5	5.0																																																																																							
20	2.5	5.0																																																																																							
25	2.5	5.0																																																																																							
30	2.5	5.0																																																																																							
35	2.5	5.0																																																																																							

LASER

Laser Product Class	Class 1 eye-safe per IEC/EN 60825-1: 2014
Laser Wavelength	865 nm
Beam Diameter Exiting Sensor	19 mm
Beam Divergence	0.09° (FWHM)

LIDAR OUTPUT

Connection	UDP over gigabit Ethernet
Points Per Second	655,360 (32 channel) 1,310,720 (64 channel) 2,621,440 (128 channel)
Data Rate (Megabits Per Second) (Legacy Mode) 2048x10	66 Mbps (32 channel) 129 Mbps (64 channel) 254 Mbps (128 channel)
Data Rate (Megabits per second) (Dual Return Profile) Not applicable for 1024x20 & 2048x10 Modes	up to 43.6 Mbps (32 channel) up to 85.6 Mbps (64 channel) up to 169.4 Mbps (128 channel)

Data Rate (Megabits per second) (Low Data Rate Profile)	up to 11.83 Mbps (32 channel) up to 22.32 Mbps (64 channel) up to 43.29 Mbps (128 channel)
Data Rate (Megabits per second) (Single Return Profile)	up to 32.81 Mbps (32 channel) up to 64.26 Mbps (64 channel) up to 127.18 Mbps (128 channel)
Data Per Point	Range, signal, reflectivity, near-infrared, channel, azimuth angle, timestamp
Timestamp Resolution	< 1 μ s
Data Latency	< 10 ms

IMU OUTPUT

Connection	UDP over 1000Base-T
Samples Per Second	100
Data Per Sample	3 axis gyro, 3 axis accelerometer
Timestamp Resolution	< 1 μ s
Data Latency	< 10 ms
Details:	InvenSense ICM-20948; datasheet for more details: https://www.invensense.com/products/motion-tracking/9-axis/icm-20948/



CONTROL INTERFACE

Connection	TCP and HTTP APIs	
Time Synchronization	Input sources: <ul style="list-style-type: none"> • IEEE1588 Precision Time Protocol (PTP); Accuracy: <1 ms error • gPTP; Accuracy: <1 ms error • NMEA \$GPRMC UART message support • External PPS; Accuracy: <1 ms error • Internal 10 ppm drift clock; Accuracy: <20 ppm error Output sources: <ul style="list-style-type: none"> • Configurable 1 - 60 Hz output pulse 	
Lidar Operating Modes	<ul style="list-style-type: none"> • x 512 @ 10 Hz or 20 Hz • x 1024 @ 10 Hz or 20 Hz • x 2048 @ 10 Hz 	
Additional Programmability	<ul style="list-style-type: none"> • Multi-sensor phase lock • Queryable intrinsic calibration information: <ul style="list-style-type: none"> • Beam angles • IMU pose correction matrix 	<ul style="list-style-type: none"> • Return ordering • Minimum range • Azimuth masking • Low-power standby mode

MECHANICAL/ELECTRICAL

Power Consumption	18 - 24 W (28 W peak at startup, 30 W peak if operating below -10 °C) Note: Ouster recommends use of a power brick (no less than 30 W) if using in extreme outdoor conditions.
Connector	Proprietary pluggable connector (Power + data + DIO)
Operating Voltage	9V - 34 V, 12 V or 24 V nominal
Dimensions	Diameter: 119.6 mm (4.71 in) Height: 102.9 mm (4.05 in)
Weight	1100 g (38.8 oz)
Mounting	Bottom: 4x M3 screws, 2x locating 2 mm pin holes, 4x M4 screws, 2x locating 3 mm pin holes, 4x M6 screws Top: 4x M4 screws, 4x locating 3mm pin holes, 1x M6 Screw

OPERATIONAL

Operating Temperature	-20 °C to +60 °C Between +52 °C to +60 °C, sensor automatically reduces range (max 20% range reduction)
Storage Temperature	-40 °C to +105 °C
Ingress Protection	IP68 (1m submersion for 1 hour, with I/O cable attached) IP69K (with I/O cable attached)
MTTF	>250,000 hours
Shock	IEC 60068-2-27 (Amplitude: 25 g, Shape: 10 ms half-sine, 400 shocks x 6 directions)
Vibration	IEC 60068-2-64 (Amplitude: 2 G-rms, Shape: 10 - 1000 Hz, Mounting: sprung masses, 3 axes w/ 8 hr duration each)
Compliance	<p>For US</p> <p>Laser Safety:</p> <ul style="list-style-type: none"> • EN/IEC 60825-1:2014 Class 1 eye safe • FDA US 21CFR1040 Notice 56 Class 1 <p>Product Safety:</p> <ul style="list-style-type: none"> • UL 62368-1 • UL 60950-22 (outdoor use) • CSA-C22.2 No. 62368-1-19 • CSA-C22.2 No. 60950-22-07 (outdoor use) <p>EMC: FCC 47CFR Part 15, Subpart B, Class A</p> <p>For EU</p> <p>Laser Safety: EN/IEC 60825-1:2014 Class 1 eye safe</p> <p>Product Safety: EN/IEC 62368-1</p> <p>EMC:</p> <ul style="list-style-type: none"> • EN 55032:2012/AC 2013; CISPR 32:2015 • EN 55024:2010; CISPR 24:2010 • EN 61000-3-2:2014 • EN 61000-3-3:2013 <p>Note: Ouster UK (Ltd): 125 Princes Street, Edinburgh EH2 4AD, Scotland, United Kingdom Contact: Neil Calder, Phone Number: +44(0).131.563.9078</p> <div style="text-align: right;">   </div>

ACCESSORIES

Included Interface Box	Polycarb/FR4, 100 g, 75 mm x 50 mm x 25 mm (LxWxH), 2 m CAT6 cable, 24 V power adapter, 5 m sensor cable
------------------------	--

SOFTWARE

Sample Drivers	Ouster SDK, ROS, C++
----------------	----------------------

EXTERIOR DIMENSIONS

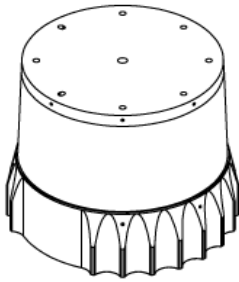

2X \varnothing 3.015 J7 ∇ 5 MIN
PIN HOLE

4X M4X0.7 - 6H ∇ 6 MIN
MOUNT HOLES

M6X1.0 - 6H ∇ 6 MIN
MOUNT HOLE

3.015 J7 X 4 ∇ 5 MIN
PIN SLOT

ALL HOLES ON
 \varnothing 89 BCD

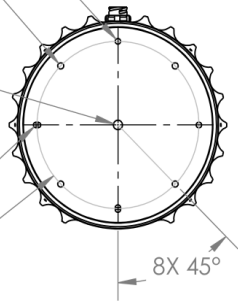

8X 45°

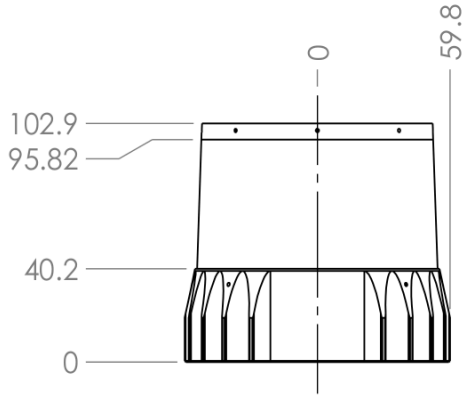
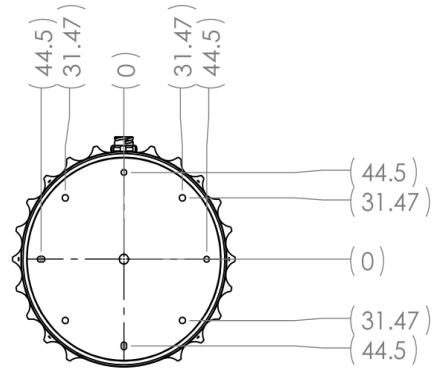

Beam Origin

78.296

0

0

13.762

27.397

FOV
KEEPOUT

22.5°

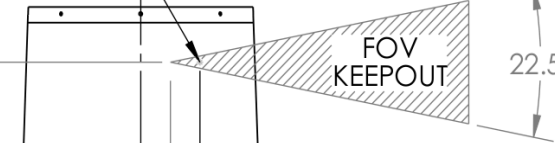

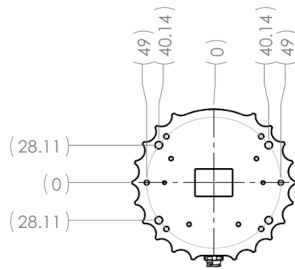

M6 Thread Pattern

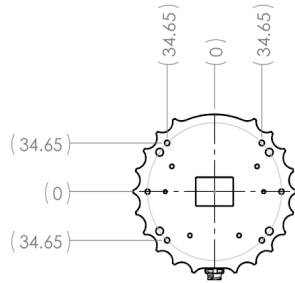
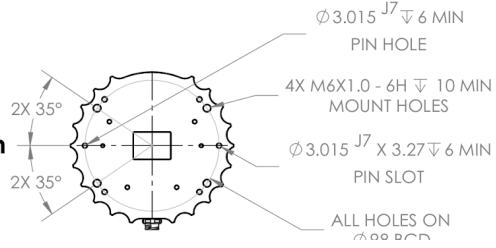

M4 Thread Pattern

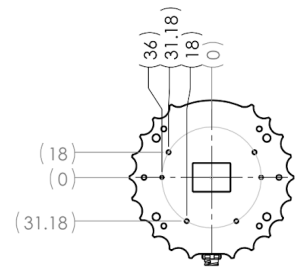
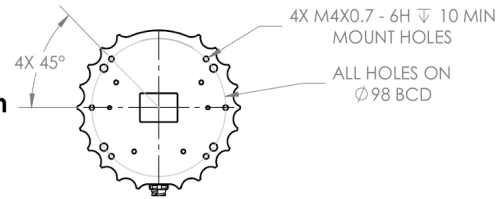

M3 Thread Pattern

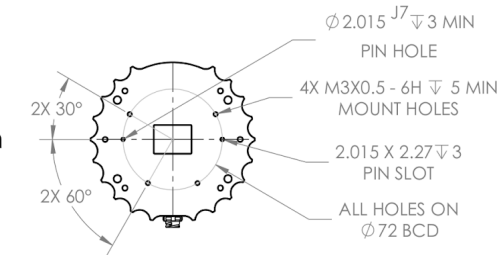

*Specifications are subject to change without notice.